

CAD FILE:

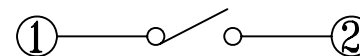

SCHEMATIC

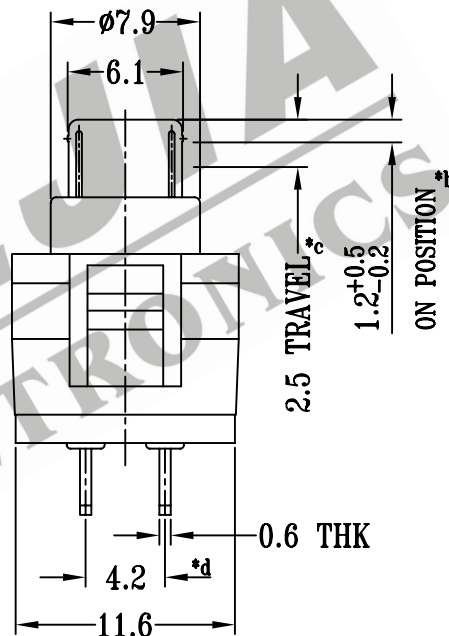
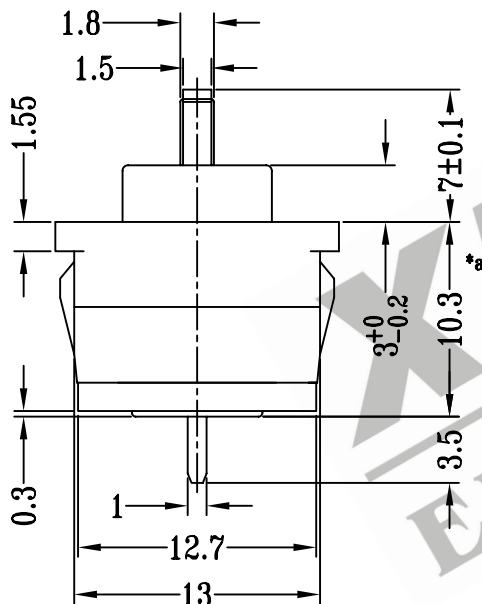
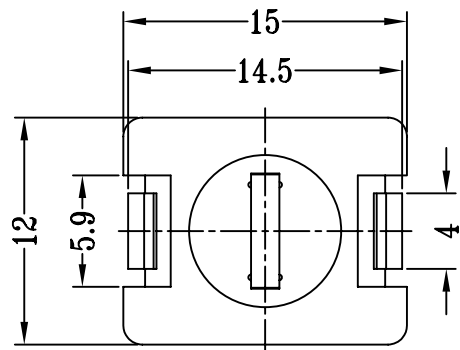
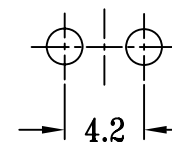

P.C.B LAYOUT

注：“*”表示关键尺寸（4个）

8					TOLERANCE UNLESS SPECIFIED	SHENZHEN XIEJIA ELECTRONICS CO.,LTD.					
7	SPRING	STAINLESS STEEL WIRE	1	TEMPER	WITHIN: 1.5±0.1mm						
6	CONTACT	BRASS	1	Ag PLATED/Au PLATED	OVER : 1.5±0.2mm	ISSUE	DATE	DESCRIPTIONS		APPD.	
5	V-TERMINAL	BRASS STRIP	1	Ag PLATED OVER Ni PLATED				TITLE : VERTICAL PUSH SWITCH		UNIT : MM	
4	U-TERMINAL	BRASS STRIP	1	Ag PLATED OVER Ni PLATED				MODEL: PB-11E01		DRWG NO.: XJ-DR-PB11E01-00	
3	CASE	NYLON + F.G	1	BLACK				SCALE: 5 : 2	DWN.	ZHOUYU	2002-3-20
2	COVER	PC	1	BLACK					CHK'D	FANGYING	2002-3-20
1	KNOB	POM	1	WHITE					APPD.	KANGXINAN	2002-3-20
NO.	PART NAME	MATERIAL	Q'TY	FINISHING	ALL MATERIALS MUST BE COMPLIANT TO ROHS						